

(No Model.)

J. W. WILBRAHAM.

ATTACHMENT TO LATHES FOR TURNING CRANK PINS.

No. 272,820.

Patented Feb. 20, 1883.

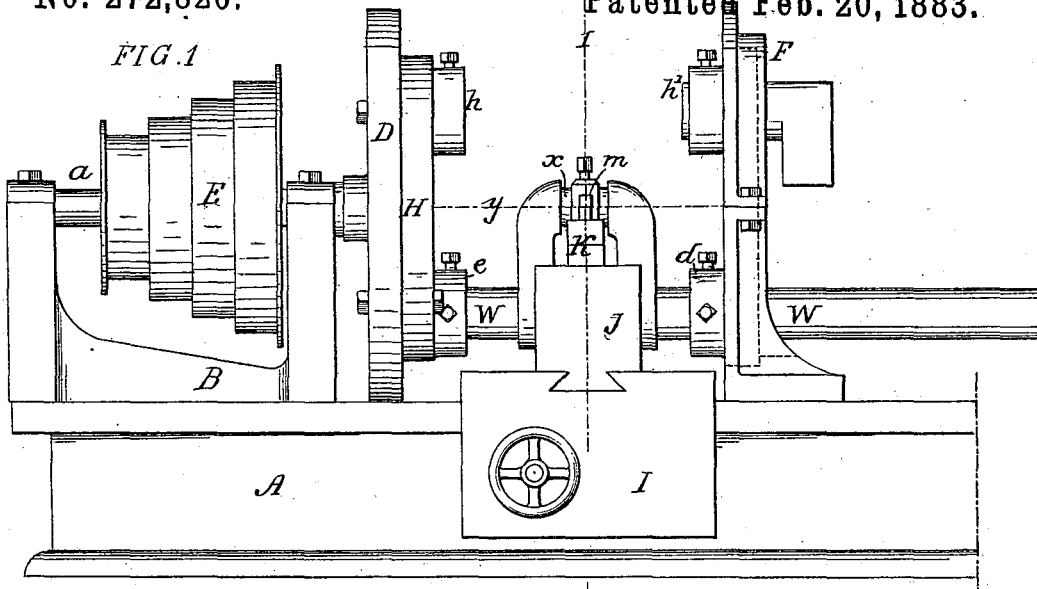
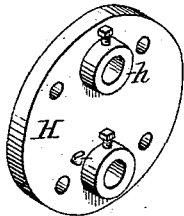

FIG. 3.



2

FIG. 2

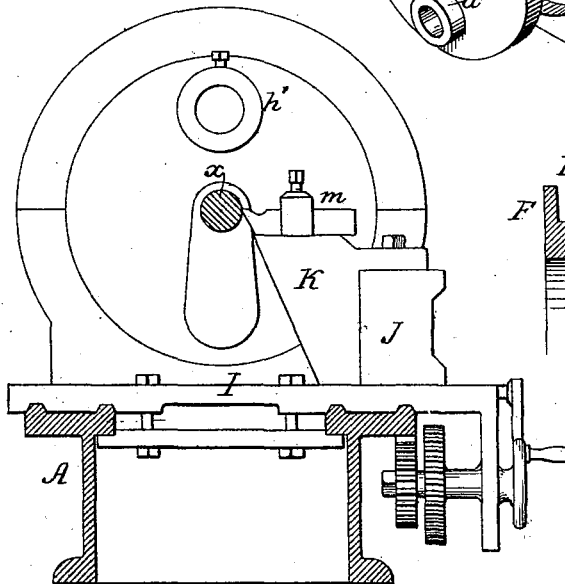

FIG. 4.

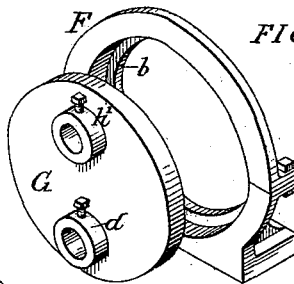
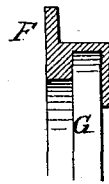

FIG. 5



WITNESSES:

James F. John
H. D. Turner

INVENTOR:

John W. Wilbraham
by his Attorneys
Howson and Sons

UNITED STATES PATENT OFFICE.

JOHN W. WILBRAHAM, OF PHILADELPHIA, PENNSYLVANIA, ASSIGNOR TO HIMSELF, AND THOMAS WILBRAHAM AND JAMES WILBRAHAM, BOTH OF SAME PLACE.

ATTACHMENT TO LATHES FOR TURNING CRANK-PINS.

SPECIFICATION forming part of Letters Patent No. 272,820, dated February 20, 1883.

Application filed September 11, 1882. (No model.)

To all whom it may concern:

Be it known that I, JOHN W. WILBRAHAM, a citizen of the United States, residing in Philadelphia, Pennsylvania, have invented certain improvements in Mechanism for Facilitating the Turning of Crank-Pins, of which the following is a specification.

My invention consists of certain attachments for a metal-turning lathe for the turning of the pins of crank-shafts, the object of my invention being the steady retention of the crank-shaft in the lathe while its pin is being turned.

In the accompanying drawings, Figure 1 is a front view of a lathe, showing the attachment for turning the pins of crank-shafts; Fig. 2, a transverse section of Fig. 1; Figs. 3 and 4, detached perspective views of parts of the device, and Fig. 5 a view illustrating a modification of part of my invention.

To the bed A of the lathe is secured the usual head-stock, B, to bearings in which is adapted the spindle *a*, carrying the cone-pulley E and face-plate D. In place of the usual following head-stock, I secure to the bed of the lathe a frame, F, having an annular recess, *b*, in which the disk G fits snugly, but so as to turn freely. On the disk G is a tubular projection or socket, *d*, and through the latter and the disk passes one straight portion of the crank-shaft W, the pin *x* of which has to be turned, the shaft being secured in its place by set-screws passing through the socket. The end of the other straight portion of the crank-shaft is fitted into and secured to a socket, *e*, on a disk or plate H, attached to the face-plate D. The center of the disk is in a dotted line, *y*, which is a continuation of the axis of the lathe spindle, and the distance from this line to the center of the socket *d* and that of the socket *e* is equal to the distance from the center of the shaft to the center of its crank-pin.

On the bed-plate is the carriage I, to guides on which is adapted a slide-rest, J, the carriage and slide being combined with traversing mechanism similar to that on ordinary slide-lathes, and hence requiring no description.

A tool-holder, K, projects from and is firmly secured to the slide-rest, and to this holder is secured the tool *m*, by which the pin *x* of the crank is turned as the crank is carried round and as the disk G revolves in its bearing.

In turning the crank-pin of a crank-shaft of the character shown in the drawings, it has been usual to secure to the straight portions of the shaft arms having centering-orifices at a distance from the center of the shaft equal to the distance of the center of the crank-pin from that of the shaft, and to adapt the centering-orifices of these arms, that of one arm to the center of the fixed head-stock and that of the other arm to the center of the other head-stock of an ordinary lathe. By this arrangement sufficient steadiness and freedom from jars could not be obtained to permit the tool to make a moderately deep and clean cut, and, moreover, the longitudinal compression of the arms between the head-stocks tended to interfere with the truth of the shaft, and thus prevent the accurate turning of the crank-pin. In my improvement, however, the steady chucking of the crank-shaft to the lathe is assured by securing the shaft at one side of the crank to the socket of the plate H, and at the opposite side to the socket of the disk G, the support for the shaft in this disk being brought much nearer to the crank, and consequently nearer to the point where the cutting takes place, than can be done when the shaft is hung by and between the centers of two head-stocks. The straight portions of the shaft may be turned before it is applied to the socket *e* on the plate H, and to the socket *d* on the disk G, these sockets being bored to suit the shaft, so that the truth of the crank-pin, when turned in respect to the shaft, will be assured.

I propose to provide the plate H with two or more sockets, so that the attachment can be used for turning the pins of cranks of different lengths. Thus, in the present instance there is an additional socket *h* on the plate H and a corresponding additional socket, *h'*, on the disk G, both these sockets being slightly nearer to the axis of the lathe than those previously referred to, these sockets *h h'* being brought into use when the pin of a crank short-

er than that on the shaft W has to be turned, and being adapted for the reception of weights to counterbalance the weight of the crank-shaft, and insure steadiness in the running of the lathe.

The frame F is preferably made of two parts, as shown in Fig. 4, and this will be necessary if the annular recess *b* is undercut for the reception of a rib on the disk, as shown in Fig.

5. As the disk is confined to its place, however, by the crank-shaft, this plan of adapting it to the frame is not necessary.

The plate H may take the place of the face-plate D; but I prefer to retain the latter, so that the lathe will be in a condition for use on

ordinary work when the above-described attachments are removed.

I claim as my invention—

The combination, in a metal-turning lathe, of the plate H and its socket *e* with a disk, G, having a corresponding socket, and with a frame forming a bearing for the disk, all substantially as set forth.

In testimony whereof I have signed my name to this specification in the presence of two subscribing witnesses.

JOHN W. WILBRAHAM.

Witnesses:

HARRY DRURY,
HENRY HOWSON, Jr.